

# TIMING BELT COMPONENTS

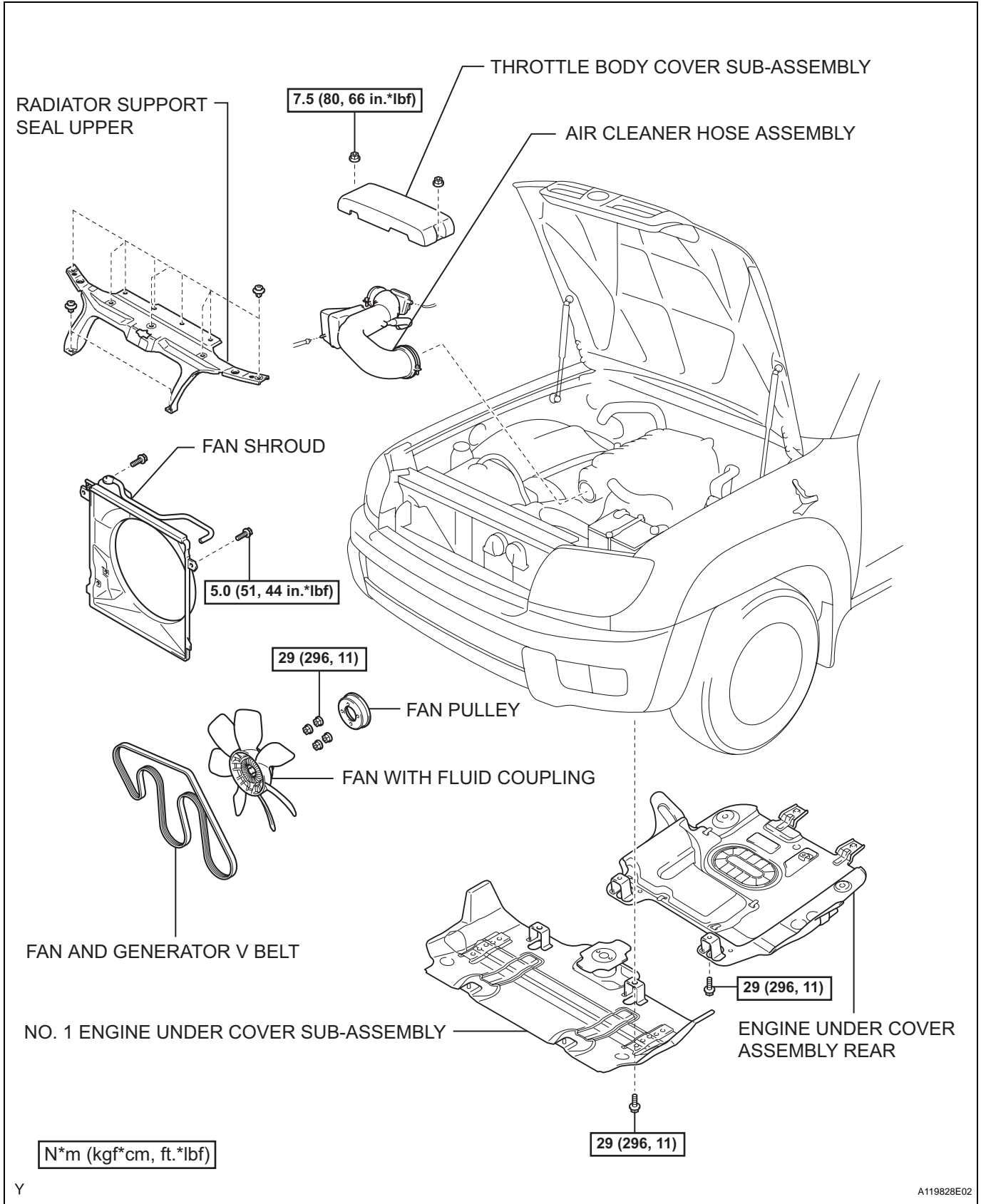

EM

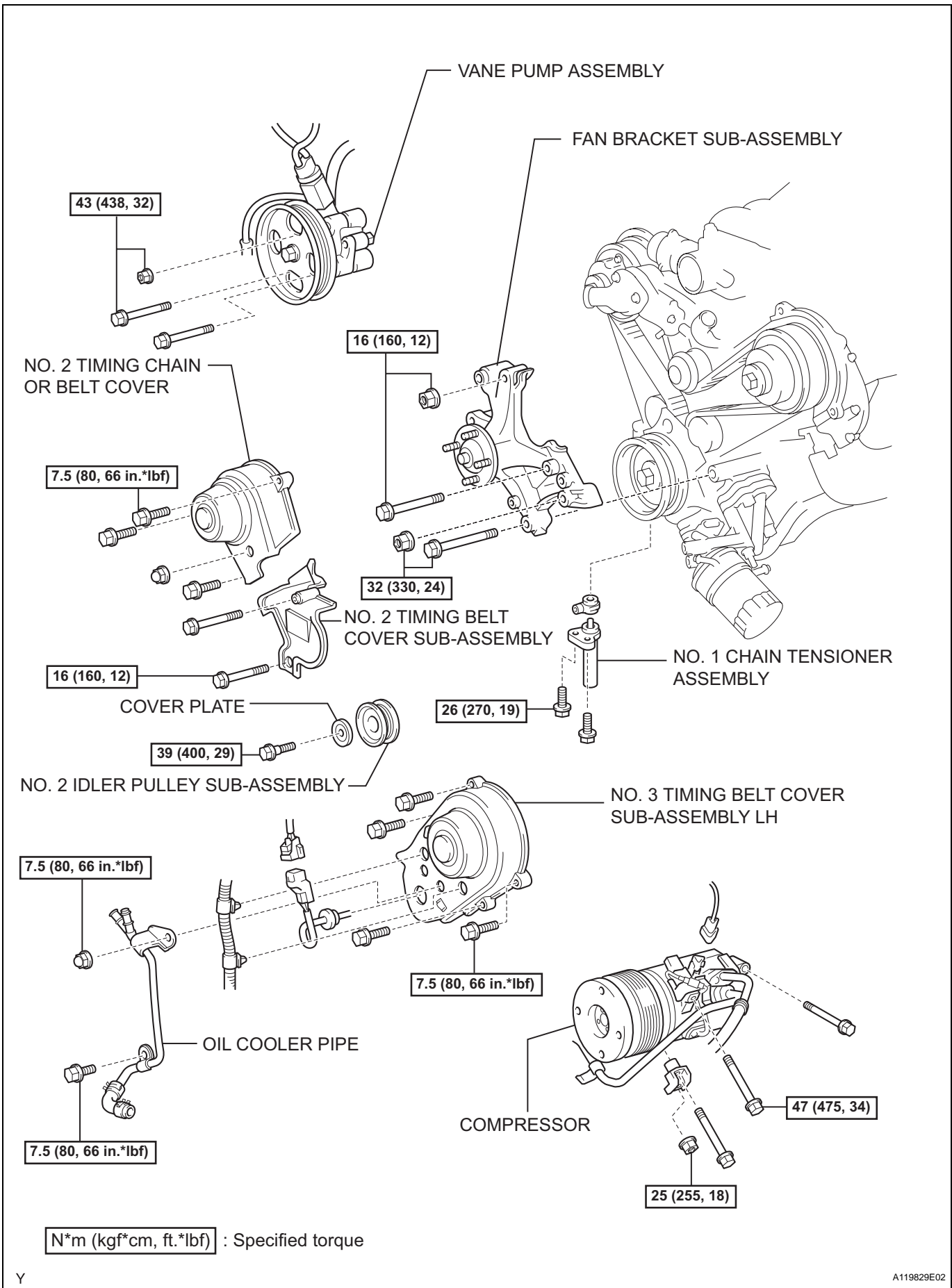

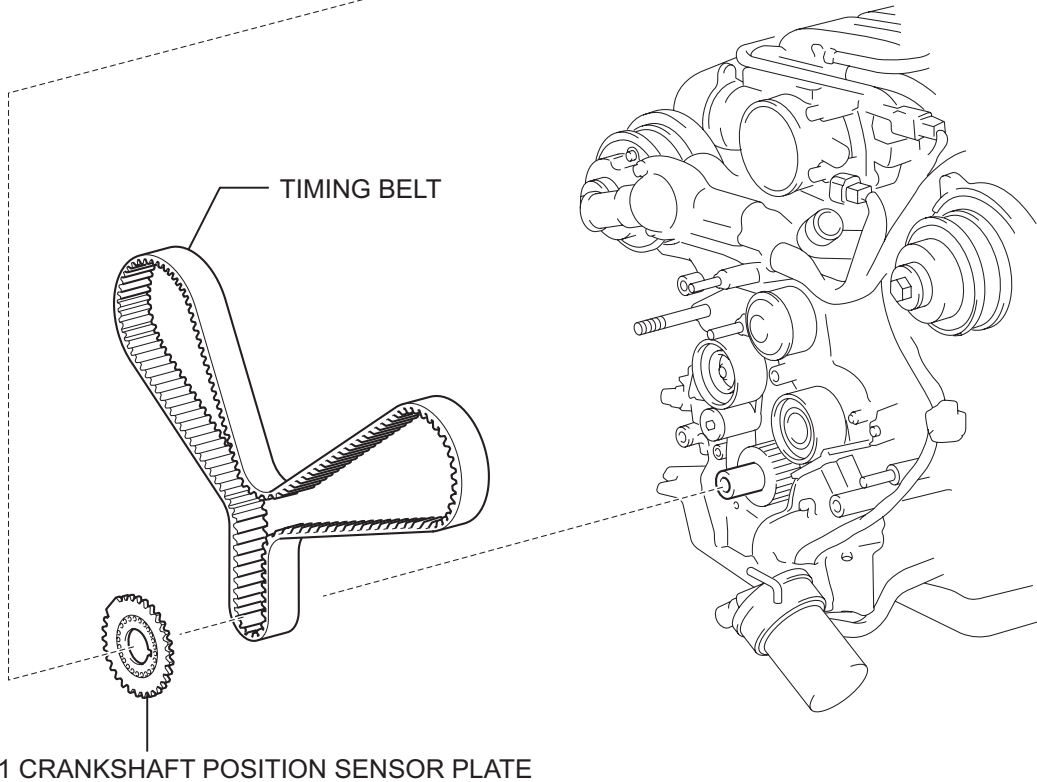
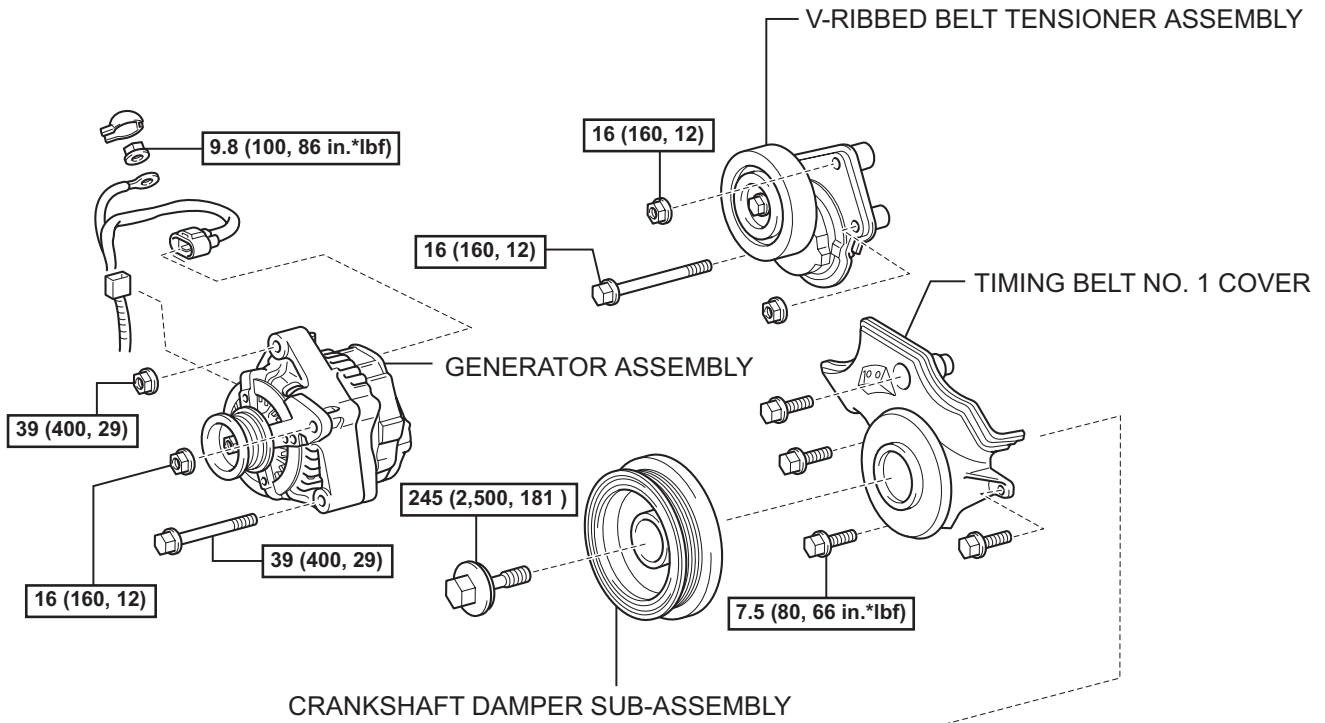

N\*m (kgf\*cm, ft.\*lbf) : Specified torque

EM